

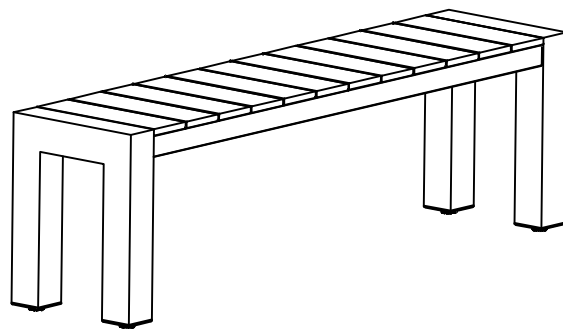

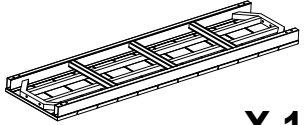

Assembly Instructions: Aluminium Bench

Before assembly please check you have all parts listed below.
PLEASE NOTE: We've tried to make this bench as easy to assemble as possible. In the unlikely event you have problems putting it together or missing pieces, please contact us.

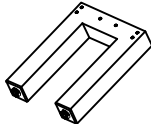
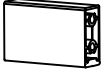
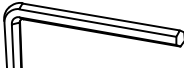
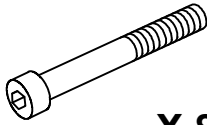

PARTS LIST

A bench top  X 1	B Legs  X 2	C bracket  X 4	D allen key  X 1	E (m6x90 screw)  X 8	F (m6x45 screw)  X 4
G (m6x12 screw)  X 8	H  X 20	I  X 20	**PROTECT YOUR BENCH DURING ASSEMBLY** To protect your bench top from scratches during assembly please assemble on the cardboard box.		

Step 1

Screw C to legs.

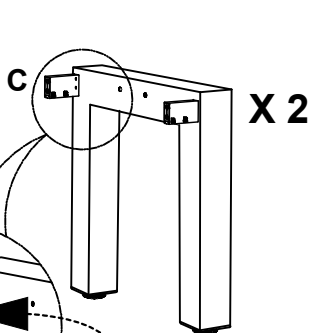

Ensure the holes are at the bottom of this bracket.

Bottom View
 (holes are furthest away from the leg)

Step 2

Slide together.

Ensure holes in bench top & leg bracket line up (see step 3).

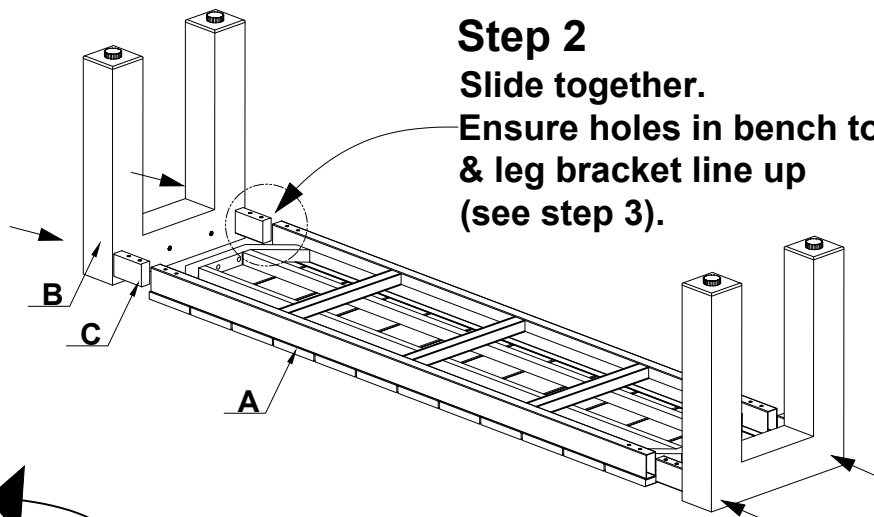

PLEASE NOTE: you only need to hand tighten this bracket (C). You may need to loosen one bracket if the bench top does not slide smoothly into place. (These do not need to be tightened further.)

Step 3

Do not over tighten screws

G
H
I

Step 4

Do not over tighten screws

I
H
F

Step 5

Now tighten all screws.

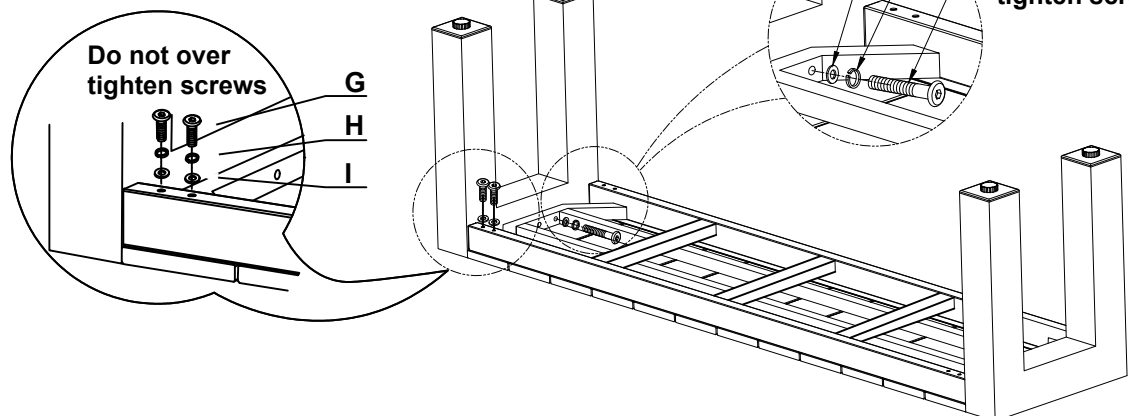

Please recycle these instructions