

ASSEMBLY INSTRUCTIONS:

Product Code : CCW1875 / RWCWS1212 / RWCWS1215 / RWCWS1218 /
RWCWS1221 / RWCWS1515 / RWCWS1818 / RWCWS2115 / RWCWS2118 /
RWCWS2121

Product Name: Rapid Worker Corner Workstation

TIME REQUIRED:

35 minutes

TOOLS REQUIRED:

Screwdriver, Electric Drill, Pencil, Measuring tape/Ruler

*Tools are not included.

SKILL REQUIRED:

Easy ●●●●○ Hard

The Assembly Skill Rating is a 5-point system that shows the degree of effort needed in assembling a specific product. With 1 being easy for the average person and 5 requiring an expert.

For most products, two persons are recommended.

Please note, as this is a commercial product, some intermediate skills are required.

*No pre-drill holes or markings are provided on tops.

This corner workstation is made of modular components. Some of the pages of this assembly guide may not be relevant to your purchased product depending on the size of the workstation.

NOTE

- As this is a commercial product, some intermediate skills may be required.
 - No pre-drill holes or markings are provided on our table or desk tops.
 - Please check you have all hardware before assembling.
- If you are missing any hardware, please contact your Rapidline reseller. Please ensure you have the name of the item, required hardware part and quantity.
 - Please retain your receipt as proof of purchase to validate your warranty.
- Assemble on a clean, flat, smooth surface such as a rug or carpet to avoid parts from being scratched.
 - Remove all wrapping materials, including staples and packing straps before you start to assemble
 - Keep all hardware parts out of reach of children.

CAUTION

- Heavy product. Do not attempt to lift or move without help
- Do not tighten screws and bolts until completely assembled.
- Do not use this product unless all bolts and screws are firmly secured and tightened.

WARNING

- If parts are missing, broken, damaged or worn stop using the product until all repairs are made.
 - Failure to follow these warnings could result in serious injury.

The logo for Rapidline, featuring the word "rapidline" in a lowercase, sans-serif font. The "i" in "rapid" has a small orange dot above it. The logo is set against a light blue rounded rectangular background.

ASSEMBLY INSTRUCTIONS

CCW96

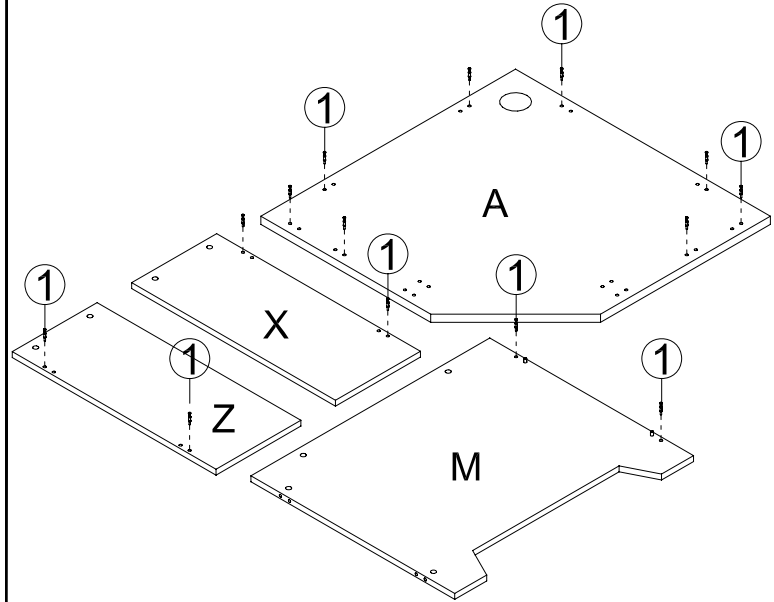
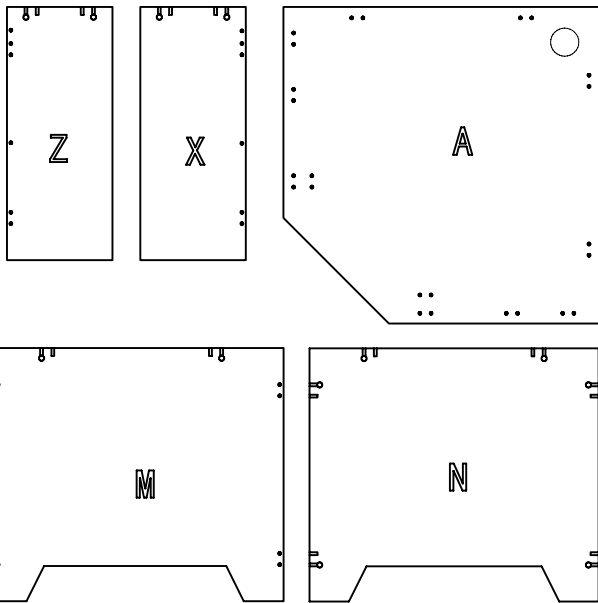
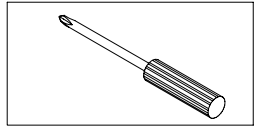
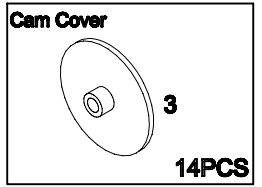
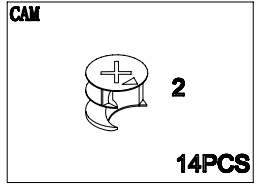
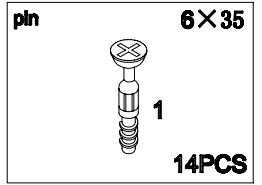
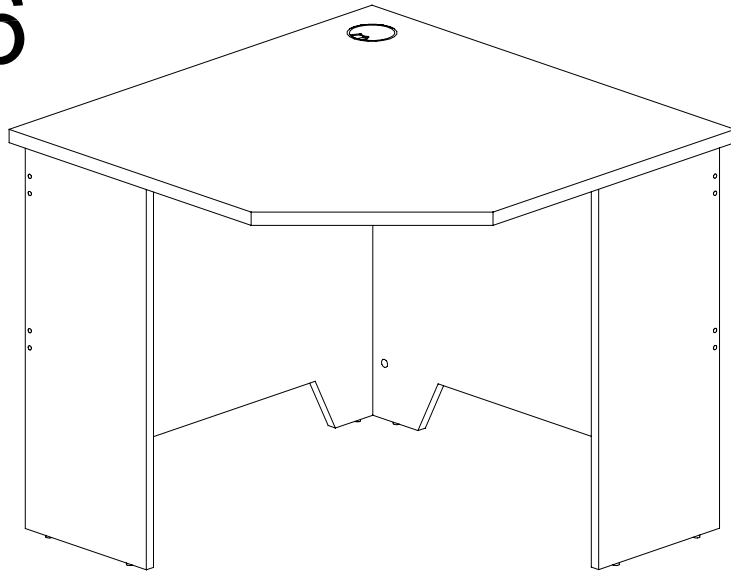

1

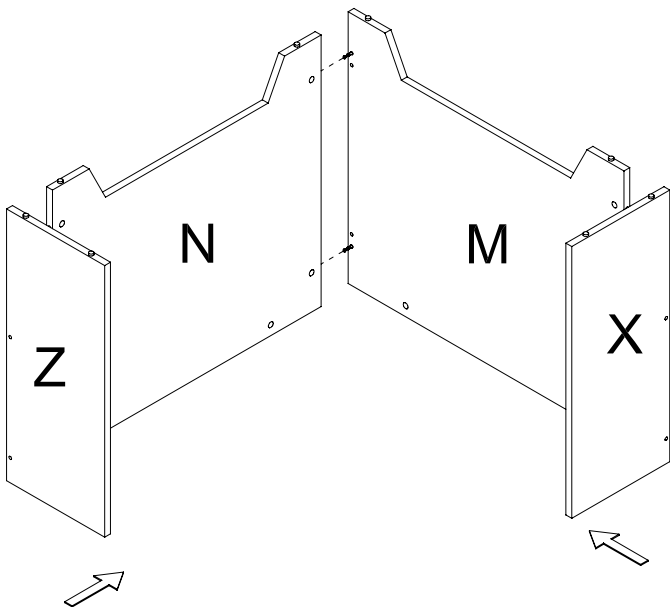



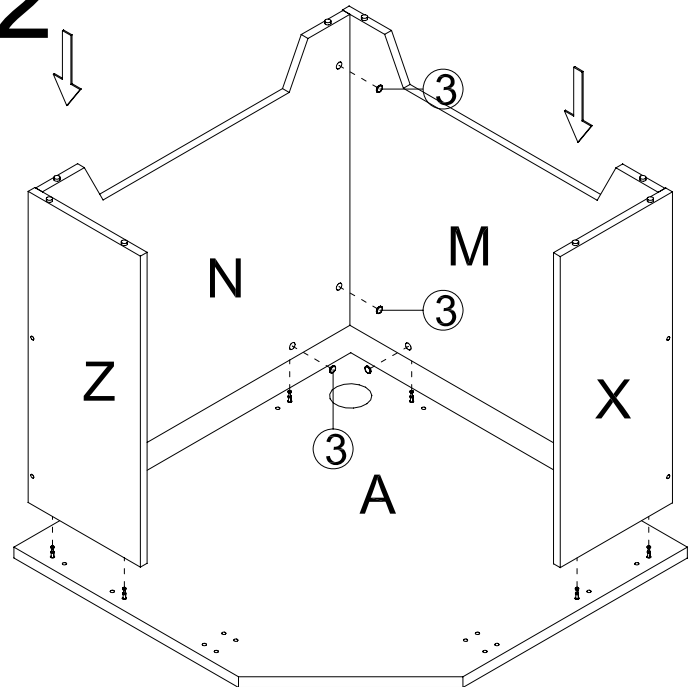



2

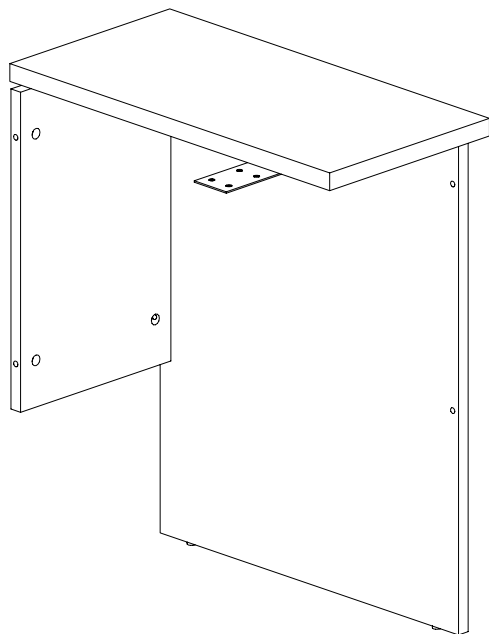

ASSEMBLY INSTRUCTIONS

CWR3

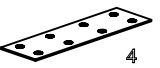

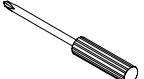

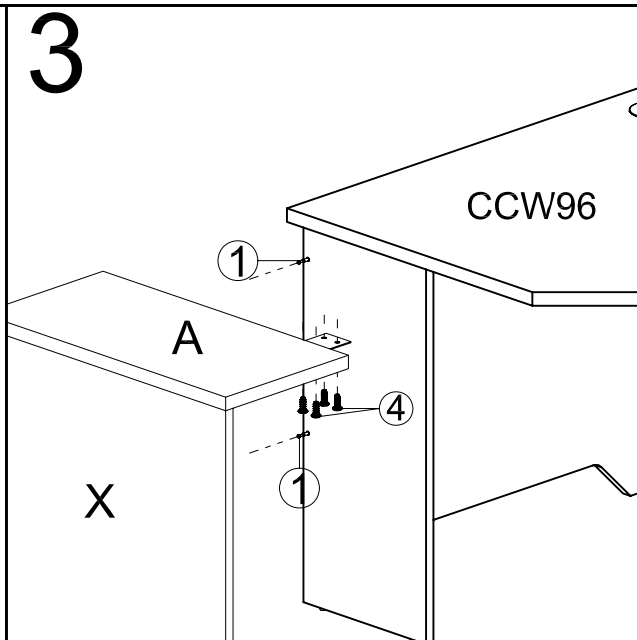
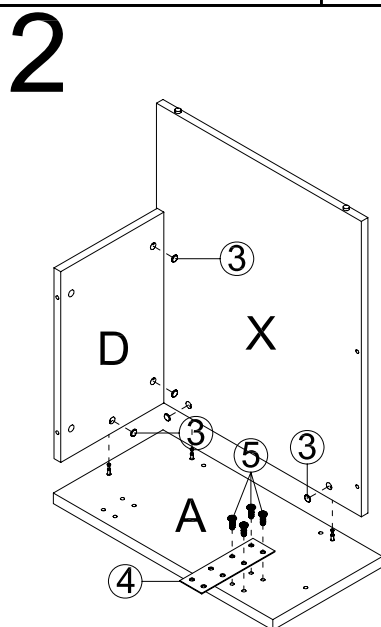
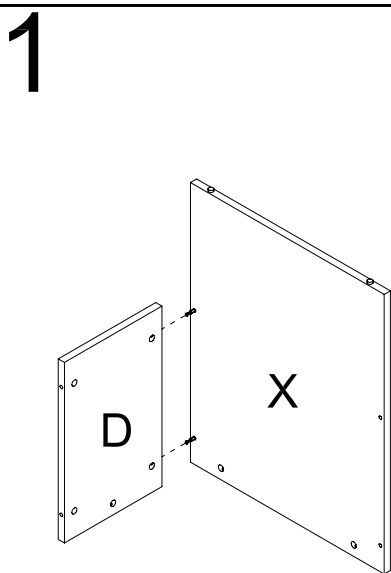
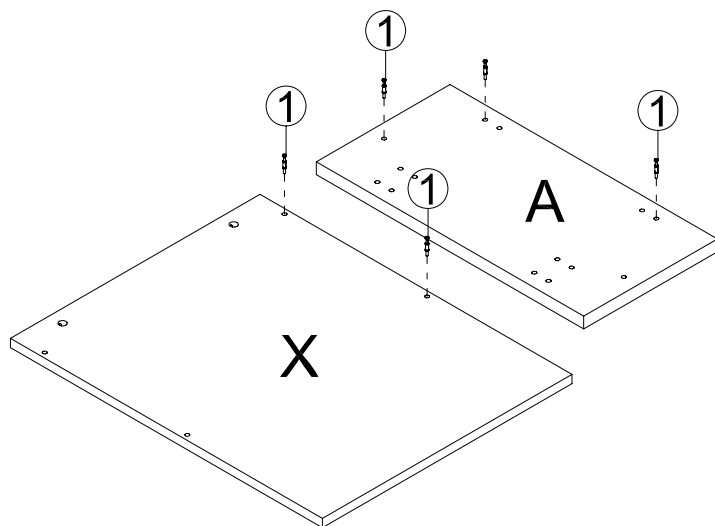
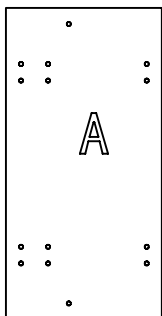
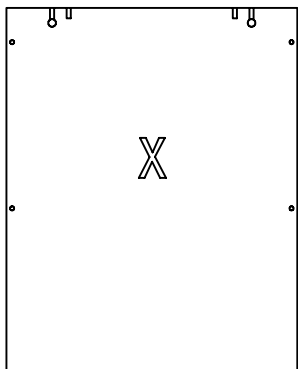
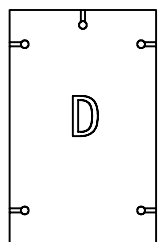



pin	6×35
	1
	7PCS
CAM	
	2
	7PCS
Cam Cover	
	3
	7PCS
CONNECTOR 200×60×2	
	4
	1PCS
Screw	6×12
	5
	8PCS
	

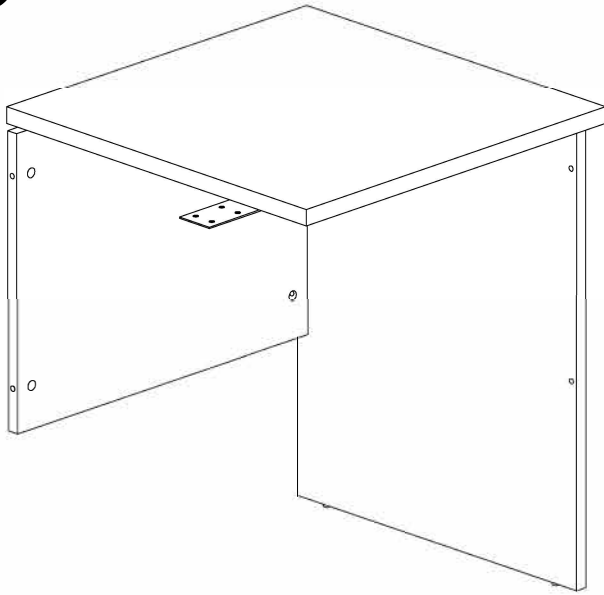

ASSEMBLY INSTRUCTIONS

CWR6

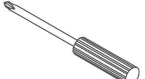

pin	6x35
	1
	8PCS
CAM	
	2
	8PCS
Cam Cover	
	3
	8PCS
CONNECTOR	200x60x2
	4
	1PCS
Screw	6x12
	5
	8PCS
	

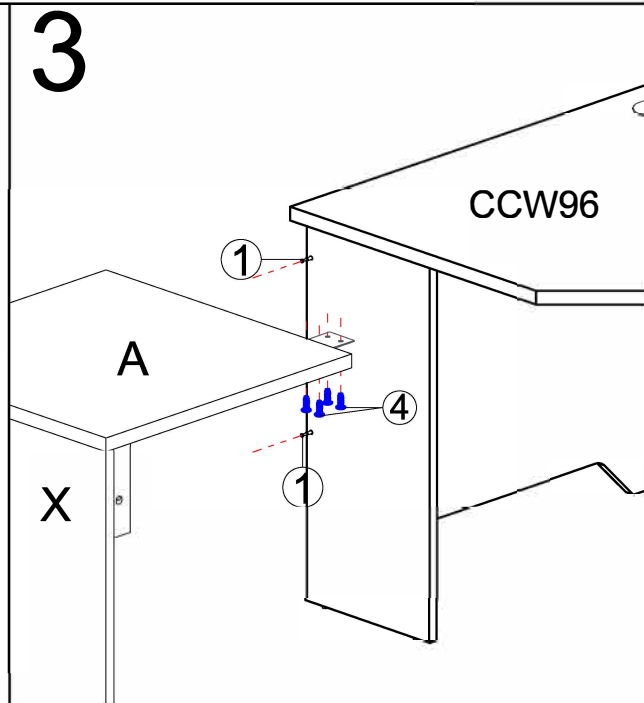
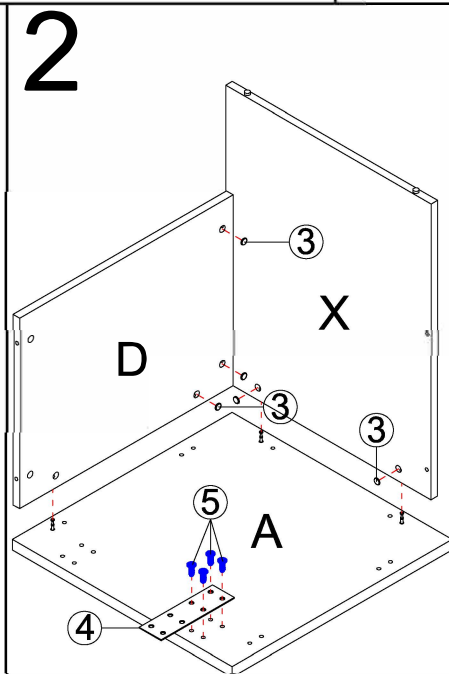
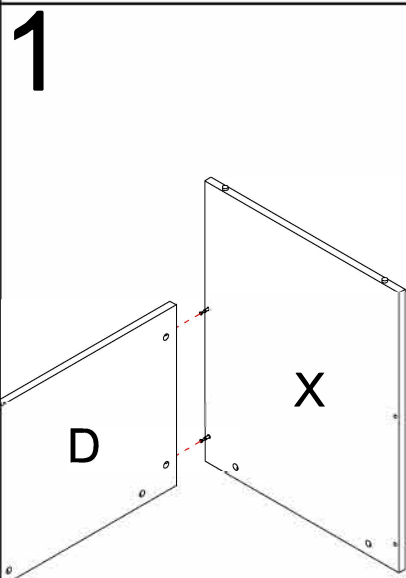
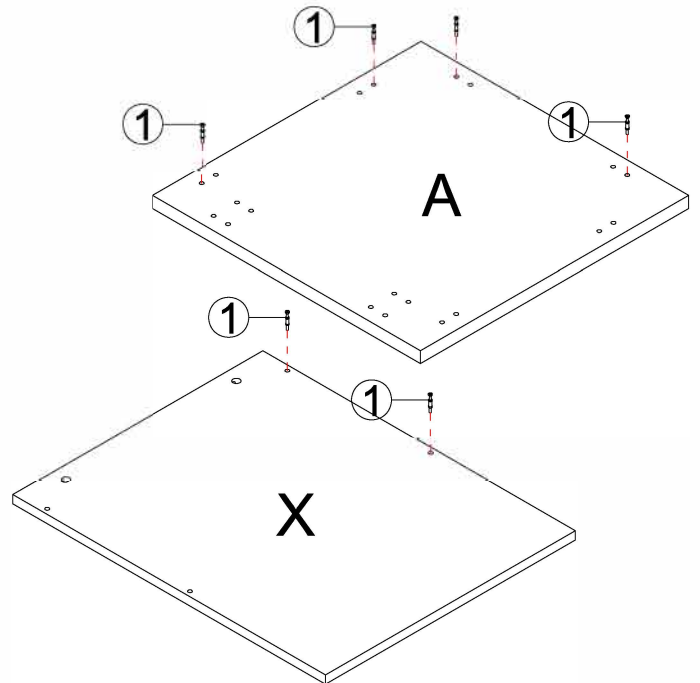
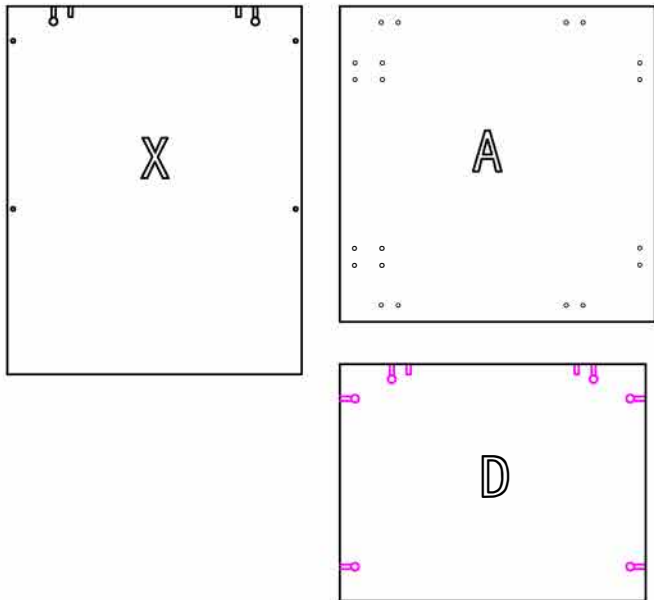



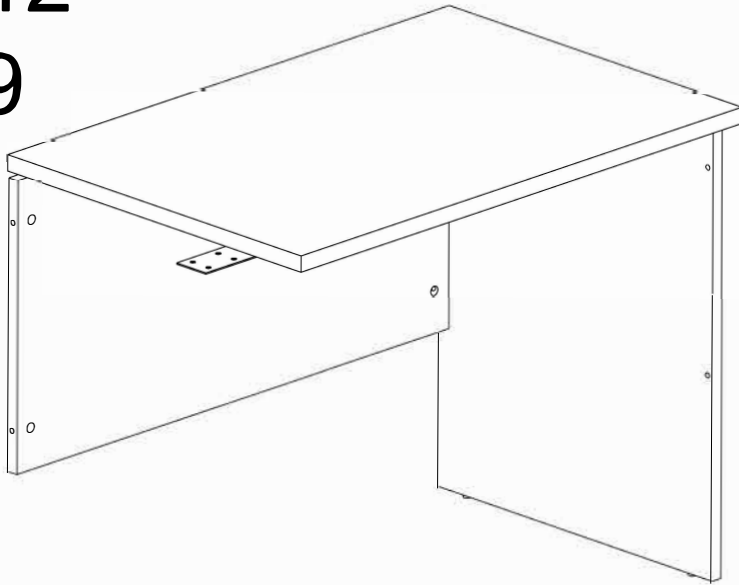

ASSEMBLY INSTRUCTIONS

CWR12

CWR9



- pin 6x35**

1
8PCS
 - CAM**

2
8PCS
 - Cam Cover**

3
8PCS
 - CONNECTOR 200x60x2**

4
1PCS
 - Screw 6x12**

5
8PCS
- 