

## ASSEMBLY INSTRUCTIONS:

Product Code : GTDSHELF

Product Name: GO Tambour Door Cupboards 900mm and 1200mm Wide

### TIME REQUIRED:

5 minutes

### TOOLS REQUIRED:

Screwdriver, Electric Drill, Pencil, Measuring tape/Ruler

\*Tools are not included.

### SKILL REQUIRED:

Easy  Hard

The Assembly Skill Rating is a 5-point system that shows the degree of effort needed in assembling a specific product. With 1 being easy for the average person and 5 requiring an expert. For most products, two persons are recommended.

#### NOTE

- As this is a commercial product, some intermediate skills may be required.
  - No pre-drill holes or markings are provided on our table or desk tops.
    - Please check you have all hardware before assembling.
- If you are missing any hardware, please contact your Rapidline reseller. Please ensure you have the name of the item, required hardware part and quantity.
  - Please retain your receipt as proof of purchase to validate your warranty.
- Assemble on a clean, flat, smooth surface such as a rug or carpet to avoid parts from being scratched.
  - Remove all wrapping materials, including staples and packing straps before you start to assemble
    - Keep all hardware parts out of reach of children.

#### CAUTION

- Heavy product. Do not attempt to lift or move without help
- Do not tighten screws and bolts until completely assembled.
- Do not use this product unless all bolts and screws are firmly secured and tightened.

#### WARNING

- If parts are missing, broken, damaged or worn stop using the product until all repairs are made.
  - Failure to follow these warnings could result in serious injury.

# ASSEMBLY INSTRUCTIONS GTD SHELF

PART LIST		
Part No	Component	Quantity
01	SHELF	01
02	SHELF SUPPORT RH	01
03	SHELF SUPPORT LH	01

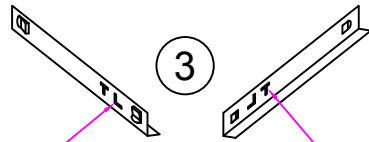
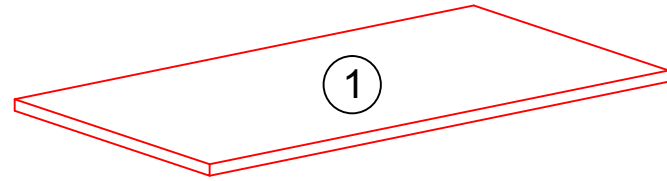

**LETTER "L" FOR LEFT HAND SIDE BRACKET**

**LEFT SIDE BRACKET**

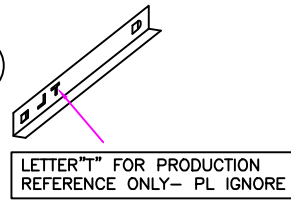

LETTER "T" FOR PRODUCTION REFERENCE ONLY- PL IGNORE

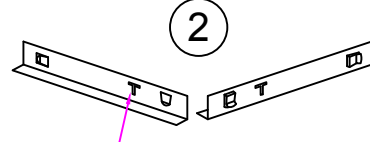

LETTER "T" FOR PRODUCTION REFERENCE ONLY- PL IGNORE

**RIGHT SIDE BRACKET**

## STEP-1

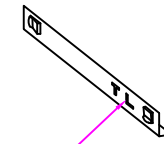

**LETTER "L" STANDS FOR LEFT HAND SIDE BRACKET**

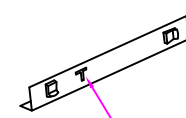

LETTER "T" FOR MANUFACTURING REFERENCE ONLY- PL IGNORE WHICH IS PUNCHED ON BOTH THE BRACKETS

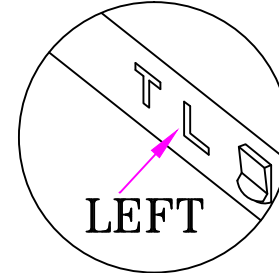

**IDENTIFICATION**

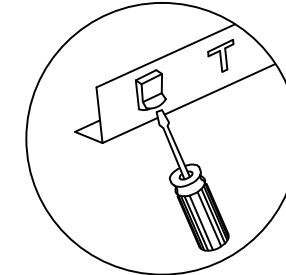

**FRONT BAYONET**

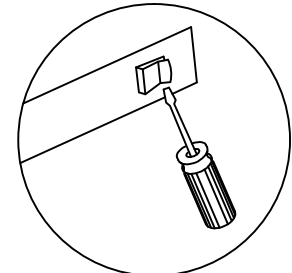

**REAR BAYONET**

1. Identify the LH and RH Brackets as shown. The Letter "L" is for Left side bracket. The letter "T" is punched on both the brackets for manufacturing identification. Please ignore the letter "T".
2. OPEN the Bayonets slightly as shown using FLATHEAD Screw driver for the easy of assembly.

## STEP-2

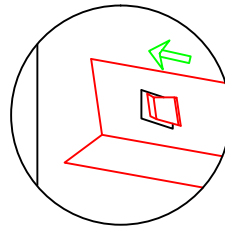
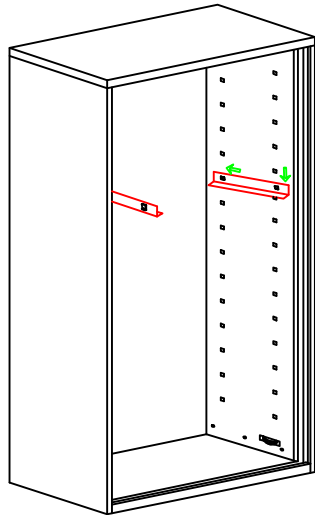

**FIXING REAR BAYONET**

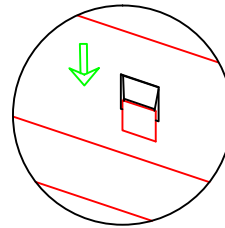

**FIXING FRONT BAYONET**

1. Position the rear bayonet of the Right side bracket in the rear slot on the inside panel and press inside as shown by the arrow direction.
2. Position the front bayonet in the front slot on the inside panel and press the bracket down ward as shown.
3. Similarly fix the left side brackets at desired position.

## STEP-3

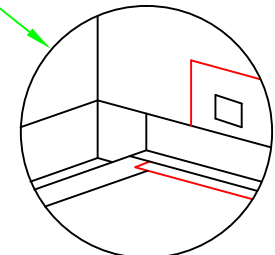
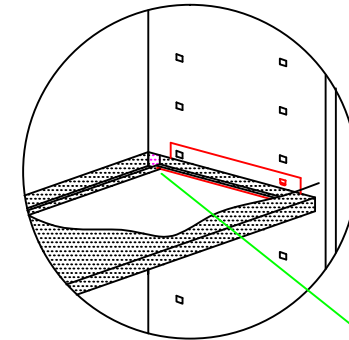
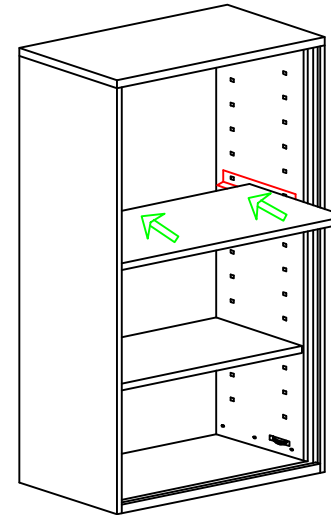

1. Position the SHELF on the shelf support brackets.
2. Press the shelf gently inside. Ensure that the shelf is locked inside the rear edge of the shelf support bracket.
3. Similarly assemble the other shelves at the desired positions.