

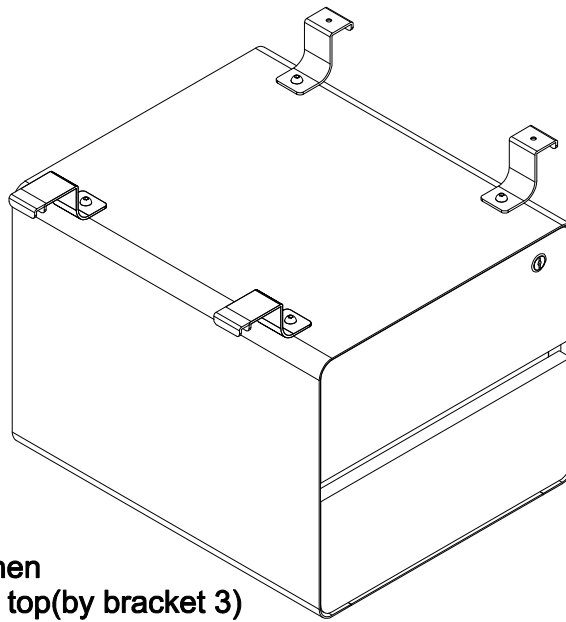



Assembly Instructions

MODEL NO: D-HP2D



Hang pedestal to the leg first (by bracket 1 or bracket 2), then connect the pedestal to the table top (by bracket 3)

Bolt Screw	8x16
	4
4PCS	
Wood Screw	5x20
	5
2PCS	
Allen Wrench	M5
	6
1PCS	

STEP1

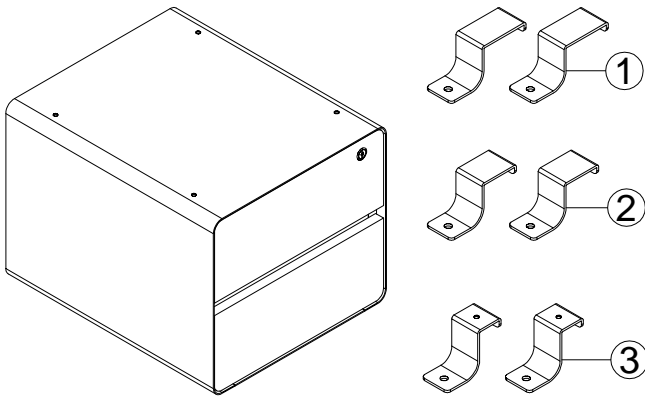

STEP2

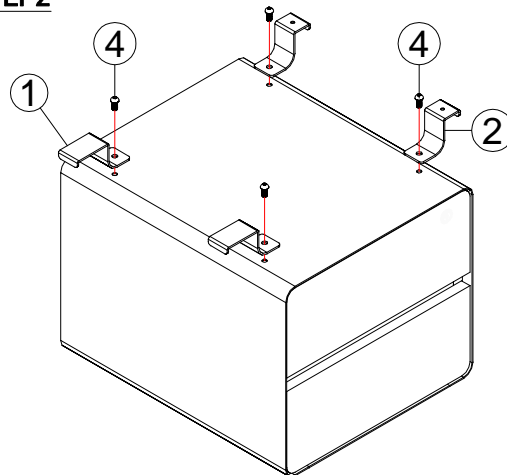

STEP3

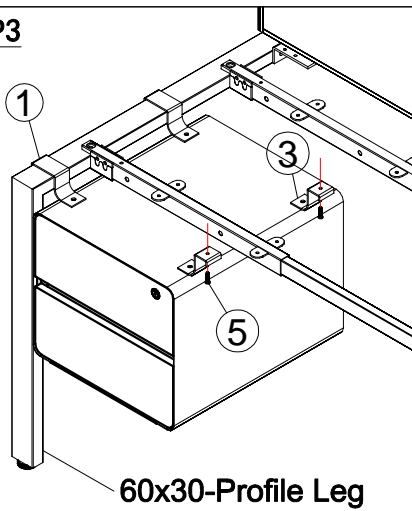

60x30-Profile Leg

STEP4

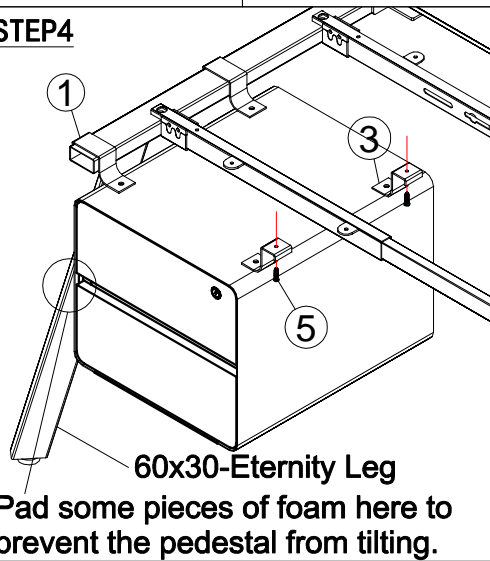

60x30-Eternity Leg Pad

Pad some pieces of foam here to prevent the pedestal from tilting.

STEP5

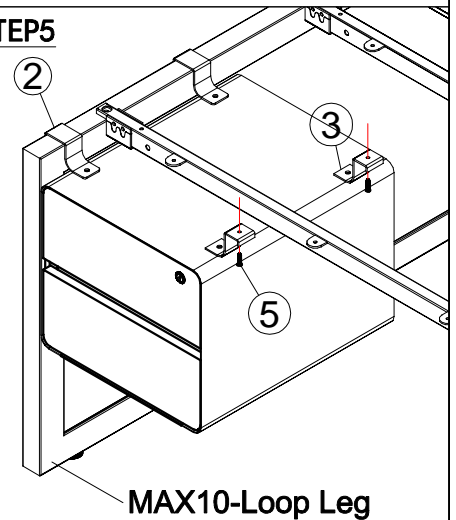

MAX10-Loop Leg

IMPORTANT NOTE:

- Place all laminated parts on a clean and smooth surface such as a rug or carpet to avoid the parts from being scratched.
 - Check to be sure that you have all parts and hardware.
 - Remove all wrapping materials, including staples & packing straps before you start to assemble.
 - Don't tighten all screws/bolts until all completely assembled.
- Keep all hardware parts out of reach of children

